

SNC01 - Ceiling Mounted Shower Nozzle

- Anti-ligature design
- Highly vandal resistant
- Normalizes the environment
- Piezo touch button activation options available
- Range of control options available

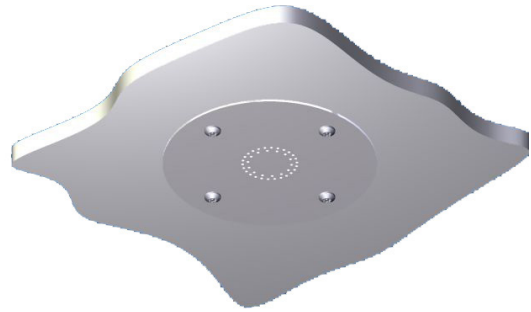

DESIGN

The SNC ceiling mounted shower nozzle is a anti-ligature vandal resistant stainless steel shower nozzle. All shower head positions can be accommodated.

The SNC range is extremely tough, being made from the highest grade stainless steel materials, this makes it ideal for the Healthcare and Secure Environments where anti-ligature and anti-vandal sanitary ware may be preferred. Water is activated by dual electronic piezo touch buttons or pneumatic push buttons.

The water is most effectively managed by Wallgate's comprehensive WDC range of electronic controllers which include timed flow, flow regulators and lockout programs.

Thermostatic mixing valves and piezo button activation-button are also available.

INCLUDED

- Ceiling mounted shower head
- NPT adaptor

TECHNICAL SPECIFICATIONS

- Supplies: 1" NPT male
- Flow rate: 1.50 gpm

MODEL SELECTION

Base Model (must specify)

- SNC01 Ceiling mounted shower nozzle

Options:

- MA1555 Box for cast ceilings
- MA1972 Box for panel ceilings



DIMENSIONS

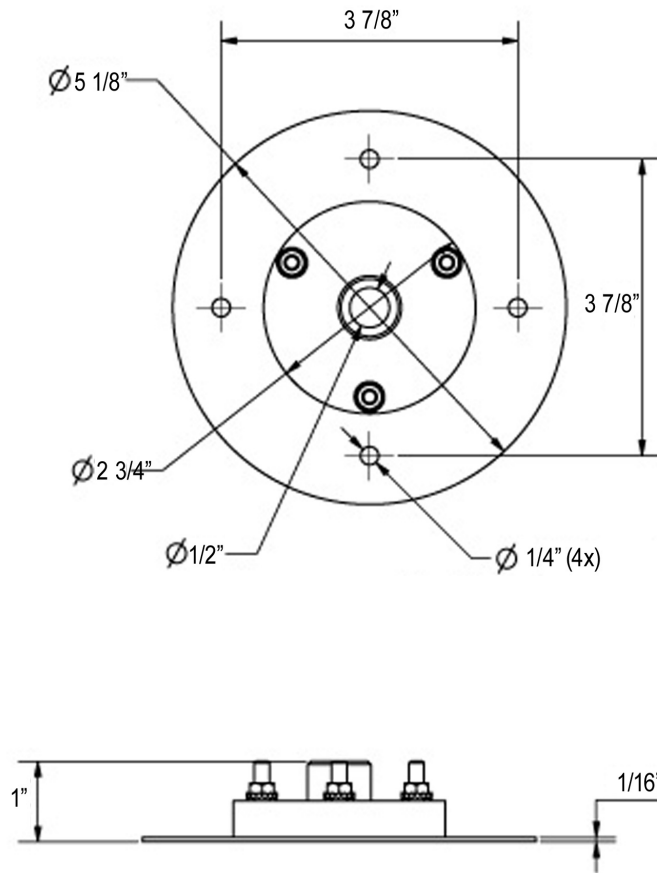

1/2" NPT male plumbing connection

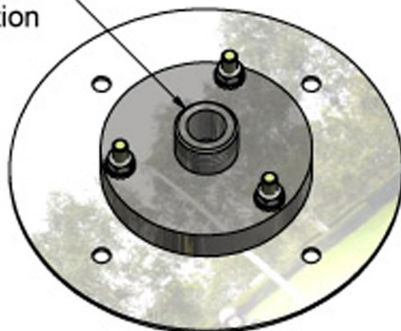

1/16" Ø spray holes

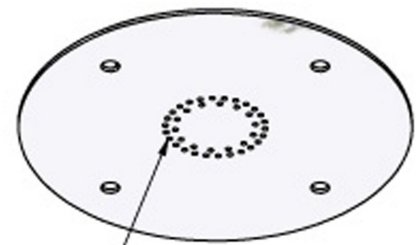

MA-OPTION

